

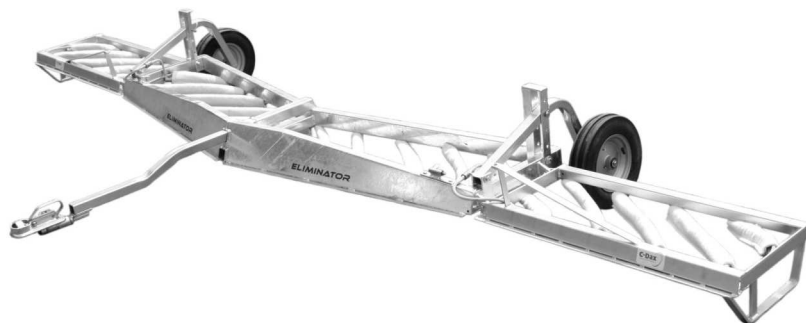

OWNER'S MANUAL
FOR THE
ELIMINATOR



&
Winged Eliminator



C-Dax Ltd
PO Box 1010, 145 Harts Road
Tiritea, Palmerston North
Ph: 06 354 6060
Fax: 06 355 3199
E-Mail: sales@c-dax.co.nz
www.c-dax.co.nz

SAFETY PRECAUTIONS

ELIMINATOR & Winged Eliminator

AN IMPORTANT MESSAGE FOR OWNERS & OPERATORS OF C-Dax ATTACHMENTS/ACCESSORIES

Be warned of the dangers of loading your ATV or other vehicle in excess of its carrying capacity. It is important to understand that any loads or attachments whether fastened to or placed on a vehicle or ATV will alter the stability or handling characteristics of that vehicle or ATV. Spray tanks or other equipment must be filled only to a level where the gross weight is within the load limit of the ATV or other vehicle.

Safety is a primary concern in the design, manufacture, sale, and use of spray tanks and other equipment. As manufacturers of spray tanks and other equipment we want to confirm to you, our customers, our concern for safety. We take this opportunity to remind you about the simple, basic and common sense rules of safety when using spray tanks and other equipment. Failure to follow these rules can result in severe injury or death to operators and bystanders.

It is essential that everyone involved in the assembly, operation, transport, maintenance and storage of this equipment be aware, concerned, prudent and properly trained in safety.

This also applies to equipment that is loaned or rented to someone who has not read the owner's manual and is not familiar with the operation of application equipment.

- NEVER EXCEED THE LOAD LIMIT CAPACITY OF THE ATV OR OTHER VEHICLE.
- ALL ATV AND TRAILED EQUIPMENT TYRES SHOULD BE INFLATED TO MANUFACTURERS RECOMMENDED OPERATING PRESSURES.
- PLEASE NOTE THAT FILLING THE SPRAY TANK OR OTHER EQUIPMENT COMPLETELY AND OR THE ATTACHMENT OF ADDITIONAL EQUIPMENT TO THE ATV MAY EXCEED THE ATV'S MAXIMUM LOAD CAPACITY, AND ADVERSELY AFFECT THE STABILITY OF THE ATV OR OTHER VEHICLE.
- CARGO SHOULD BE PROPERLY DISTRIBUTED AND SECURELY ATTACHED.
- REDUCE SPEED WHEN CARRYING CARGO OR PULLING A TRAILER OR TRAILED APPLICATION EQUIPMENT AND ALLOW GREATER DISTANCE FOR BRAKING.
- NEVER ALLOW ANYONE TO RIDE ON YOUR SPRAYER OR OTHER EQUIPMENT.
- ALWAYS FOLLOW THE INSTRUCTIONS IN THE OWNER'S VEHICLE MANUAL FOR CARRYING CARGO OR PULLING A TRAILER.
- PROPER MAINTENANCE IN LINE WITH MANUFACTURER'S RECOMMENDED MAINTENANCE PROCEDURES IS ESSENTIAL.
- BEFORE APPLYING CHEMICALS, READ THE LABEL OF THE CHEMICAL MANUFACTURER OR SUPPLIER FOR PERSONAL PROTECTIVE EQUIPMENT AND OPERATE AS RECOMMENDED.
- THE SAFETY OF ALL CHEMICALS USED IN AGRICULTURE IS UNDER THE JURISDICTION OF A GOVERNMENT AGENCY, IE N.Z. MINISTRY FOR THE ENVIRONMENT; USA ENVIRONMENTAL PROTECTION AGENCY. FURTHER LOCAL GOVERNMENT OR STATE LAWS MAY APPLY.

Throughout this manual there are highlighted text boxes containing warnings, cautions and notes.

Warnings are mandatory instructions to prevent serious injury or permanent damage.

Cautions are advisory instructions to ensure reliable operation of the equipment.

Notes are for convenient operation.

C-Dax ELIMINATOR & Winged Eliminator

OWNER'S MANUAL

(Pt.No.2400-5800 Issue 12 Dated 01 December 2010)

TABLE OF CONTENTS

2	Safety Precautions
3	Contents
4	Warranty
	Liability
5	Description
	Order Information
	Optional Equipment
	Assembly
6	Frame
	Hose Assembly
7	Bypass Fitting
	50 and 80 Litre Sprayrider Tanks
	60 and 100 Litre Sprayrider Tank
	200 Litre Tank
8	<i>Spraymate 50</i>
	Spraymate 30, Spraymate 100, and Sprayrider 45
	Control Panel
	Testing
9	Wiping
	Chemical Application
	Chemical Advice
	Herbicide Rates
	Adjuvants
10	Calibration
	Height Adjustment
11	Application Rates
	Maximum Speeds
12	Setting the Flow Rate
	Maintenance
	Flushing
	Filters
	Carpets
	Frame
	Wheels and Tyres
13	Trouble Shooting
14	Exploded Parts Diagram
15	Parts List

WARNING

The Winged Eliminator utilizes a latch mechanism to hold the wings in the upright position. Extreme care must be taken to ensure that the wings are in the upright position before proceeding through gateways. The latch mechanism should be regularly inspected to ensure that the latches are engaging fully and the wings are remaining upright.

WARRANTY

C-Dax LTD warrants to the original purchaser that the equipment is sold free from defects in materials and workmanship for a period of 12 months from date of retail sale (6 Months from date of retail sale for all equipment sold in the U.K.).

Accordingly, C-Dax LTD undertakes to repair the equipment, or at our option replace, without cost to the original purchaser either for materials, parts or labour, any part which within the specified warranty period from time of delivery is found to be defective. PROVIDED that the equipment has been used for normal purposes in accordance with the instructions, and has not been subject to neglect, misuse or accident, and has not been repaired, serviced or dismantled by any person other than a service agent or person authorised by C-Dax LTD.

The warranty does not extend to cover: consequential damage; repair or replacement of parts due to fair wear and tear; or damage resulting from neglect, misuse, accident or hireage. SPECIFICALLY the warranty excludes battery damage, damage arising from chemical attack, and units built to customers specifications.

All goods returned to C-Dax LTD are freight paid by the **sender** and if subject to a warranty claim, **must** be accompanied by a completed warranty claim form. Warranty claim forms are available from C-Dax dealers.

LIABILITY

The maximum liability, which is accepted by C-Dax LTD, is limited to replacement of faulty goods only. Every care has been taken in the manufacture of our goods but because use of the goods is outside the control of the manufacturer, the end user assumes all responsibility for the use. Neither the manufacturer nor retailer shall be liable for loss or damage resulting from use.

Any advice or recommendations given by C-Dax LTD, its agents, or employees is given in good faith and based on the best information available to us. No liability or responsibility is accepted or implied as a result of any information or advice tendered by C-Dax LTD, its agents or employees. The end user accepts all responsibility arising from that advice.

DESCRIPTION

The C-Dax Eliminator is the latest model in the popular C-Dax weed wiper range of products. It is a trailed wiper with a 2340mm effective width (or 4.3m effective width for the Winged Eliminator) and has been designed for maximum strength with minimum weight. All wiping loads are taken on the vehicle tow bar.

The C-Dax Eliminator is a very powerful tool in the fight against erect weeds such as rushes, fern, annual buttercup, ragwort, docks, and thistle. Control of these weeds is now easy and environmentally and operator friendly. The unique extended wiping action ensures that in most cases only one pass is required at speeds of up to 12 kph. Very little herbicide is wasted because only the weeds are contacted. Wiping can be done on hillsides and in windy conditions.

The Eliminator has four wiping heights from approximately 50mm to 350mm and is compatible with the C-Dax Sprayrider, Spraymate, and SO200 series of 12VDC powered sprayers. Each Eliminator is supplied with an electronic pump control unit for hands-free operation.

The Eliminator employs a unique C-Dax pressurised feed system to ensure even flow of spray fluid across the wiper frame irrespective of the slope of the area being wiped.

ORDER INFORMATION

	<u>NZ</u>	<u>EXPORT-AUS & UK (Both with 50mm HITCH)</u>
Eliminator	1015	1015
Winged Eliminator	1016	1016

OPTIONAL EQUIPMENT

Electronic Control Panel	1500-4300	Electronic pump controller
50L Onboard Tank Unit	1017	Allows the Eliminator to be operated without an external spray tank (includes pump).

ASSEMBLY

NOTE

To aid assembly, exploded parts diagram of the Eliminator is shown at the end of this document.

Unpack the Eliminator and check the contents. Each Eliminator is shipped assembled in kit form. Each kit contains the wiper frame, draw bar, left and right hand wheel assemblies, and parts kit.

The standard Eliminator parts kit contains the following parts:

Part	Description	Qty
1500-4300	Cable-Electrical-Loom-Eliminator-Control Box	1
5600-1300	Packaging-Carton-380Lx380Wx130D-Printed	1
8427-4200	Sub-Hose Assembly-Wiper-Eliminator	1
2400-5800	Document-Manual-Eliminator-G2	1
1018-3921	Adjuster-Height-Eliminator-RH-ZP	1
1018-3920	Adjuster-Height-Eliminator-LH-ZP	1
2000-0013	Clamp-Hose-Herbi-E-Ratchet-13.1<>15.1mm-Black-Nylon	2
2000-0015	Clamp-Hose-Herbi-F-Ratchet-15.0<>17.1mm-Black-Nylon	2
2000-4008	Clamp-Hose-Worm Drive-Jubilee-8mm-Stainless	1
2840-1290	Fastener-Bolt&Nut-Hex-8.8 Grade-M12x90-ZP	4
3170-0012	Fastener-Nut-Nyloc-M12-ZP	4
3310-5012	Fastener-Washer-Flat-Heavy-M12x32x3-Galv	8
5300-5000	Nozzle-Plate-Teejet-Orifice-0.055in-SS	1
5600-1160	Packaging-Bag-Plastic-Zip Seal-180x255mm	1
6100-4780	Pin-Locking-10x57mm-ZP	1
6100-4800	Pin-Locking-11x100mm-ZP	2
6200-7210	Pipe-Fitting-Quick Release-Male Connectorx8.5 Shank-Brass	1
6200-7240	Pipe-Fitting-Quick Release-Valve-1/4BSPM-Brass	1
6200-7250	Pipe-Fitting-Quick Release-Valve-Stopx8.5 Shank-Brass	1

Frame

Attach the left and right wheel assemblies to the frame using the M12 bolts, washers and nyloc nuts. There is a left hand and right hand height adjuster. The flats on the height adjusters should face the outside of the frame. Ensure that the nuts are done up tight so that there is no sideways movement of the wheel assembly. Lift the wiper frame to the desired wiping height and insert the large lock pins through the corresponding holes. Secure the lock pins with the spring clip. Insert the drawbar into the appropriate socket to match the height of the ATV tow ball. Ensure that the wiper frame is level (if necessary invert the draw bar to obtain the correct height). Secure the draw bar with the small lock pin provided and latch the pin with the spring clip. Attach the Eliminator to the vehicle tow ball, ensuring that the tow hitch size is correct for your vehicles tow ball.

Hose Assembly

Use the diagram on the following page to aid hose assembly.

1. To connect the Eliminator to the sprayer, the delivery hose from the sprayer must be modified. Cut this hose at a convenient point and fit the brass quick release valve to the end.

NOTE

A brass hose shank is provided to allow the original hose to be reconnected to the sprayer when the Eliminator is not being used.

2. Connect the hose assembly into the delivery hose quick coupler ensuring that the fitting with the white T is connected to the quick coupler.
3. Route the long end of the hose assembly to the Eliminator, cut to length and connect to the plastic T fitting at the centre of the frame. Use the supplied jubilee clip to connect the two.
4. Secure all hose connections with the nylon hose clips provided.

NOTE

Use the 'E' clamps on 8.5mm hose and the 'F' clamps on the 10mm hose.

5. To prevent snagging the delivery hose it is recommended that it be temporarily secured to the Eliminator drawbar using tape.
6. To complete the installation a bypass fitting will need to be fitted into the spray tank. Most C-Dax spray tanks have a threaded fitting moulded in for this purpose. See instructions on following page for bypass installation.

Winged Eliminator

In addition to the assembly detailed above, the left hand and right hand self angling wings need to be bolted to the centre section. To find the right hand and left hand wing, align the frames so that the 'bruise bars' on all sections are facing forward. Each wing is bolted through two hinges at either end of the centre section using two M8x40 bolts, four heavy M8 washers and two M8 Nyloc nuts. For assembly detail refer to the exploded parts diagrams at the end of this manual.

To connect the plumbing to each wing simply connect the male quick coupler on the wing to the female coupling on the centre section. These quick couplers are self sealing and therefore give the option of leaving the couplers disconnected and the wings in the upright position, utilizing only the centre section if desired.

WARNING

Always check Eliminator wings are in the upright position before proceeding through gates.

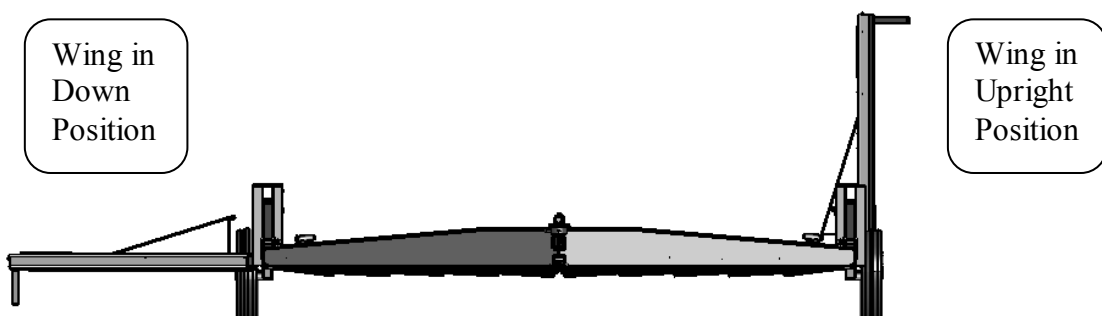

Eliminator Hose Assembly

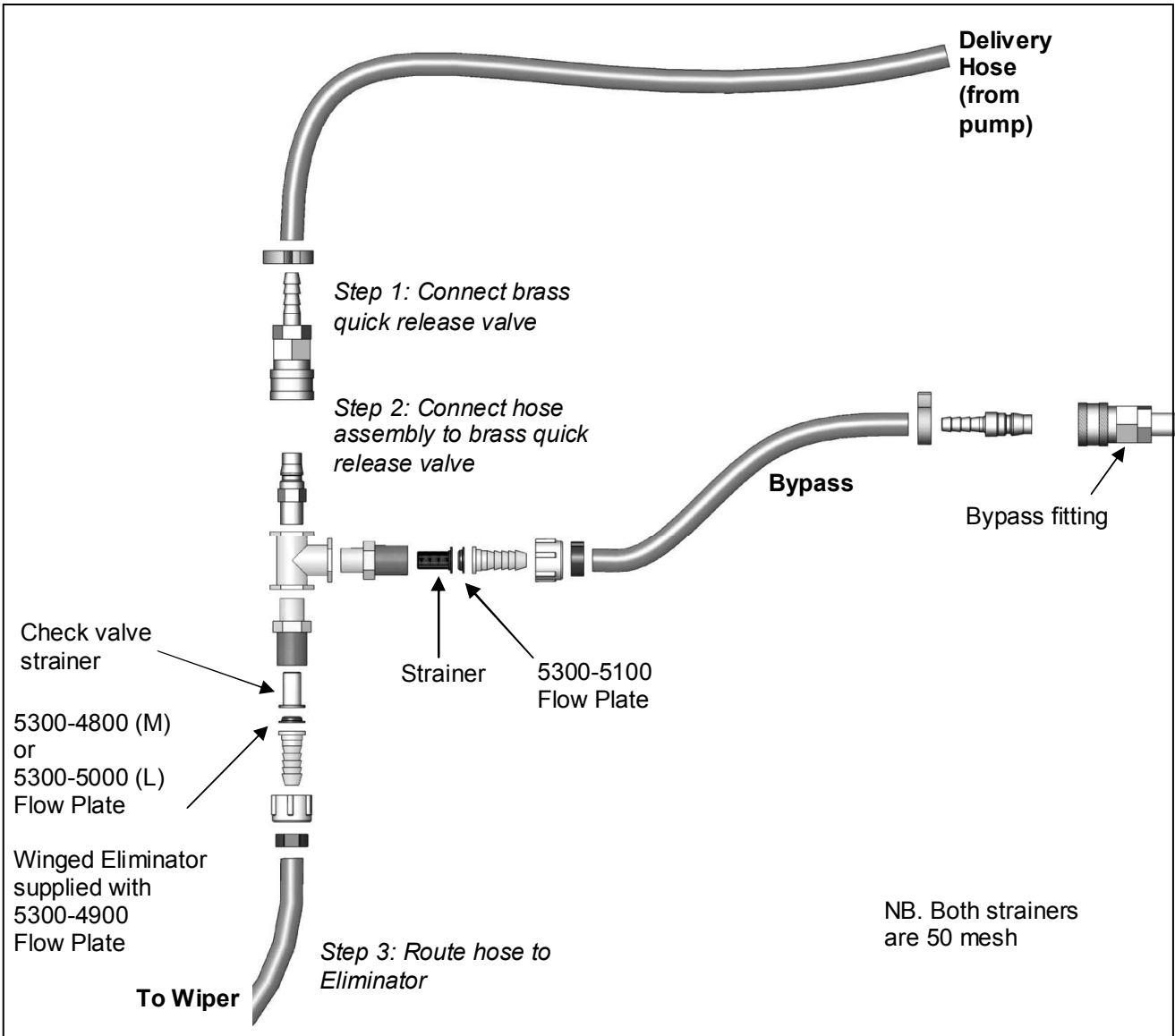

Bypass Fitting

50 and 80 Litre Sprayrider Tanks

1. Locate the brass insert in the tank rear wall under the blue fresh water tank, and carefully drill out the plastic using a 10mm drill bit.
2. Screw the 10 mm brass quick-coupler into the insert as shown below.
3. Connect the short hose of the Eliminator hose assembly to this tank connection.

60 and 100 Litre Sprayrider Tank

1. Remove the pump cover to expose the ¼" BSP brass insert in the back of the tank.
2. Carefully drill out the plastic from inside the insert using a 10mm drill bit.
3. Drill a 25mm hole in the pump cover in line with the brass insert. There is a small dimple in the cover to mark the position of the hole.
4. Screw the 10 mm brass quick-coupler into the insert and replace the pump cover.
5. Connect the short hose of the Eliminator hose assembly to this tank connection.

200 Litre U200 Tank

1. Locate the brass insert in the tank wall and carefully drill out the plastic using a 10mm drill bit.
2. Screw in the 10 mm brass quick-coupler either directly or using an elbow (200L only).
3. Connect the short hose of the Eliminator hose assembly to this tank connection.

Spraymate 50

The following additional parts (not supplied in parts kit) are required to connect the return line quick release valve to the SM50 tank:

<i>Part No.</i>	<i>Description</i>	<i>QTY</i>
4500-1300	Bypass provision asy	1

1. Locate the brass insert in the top of the tank and carefully drill out the plastic using a 10mm drill bit.
2. Apply some pipe thread sealant to the threaded connector and screw the connector to the nylon elbow.
3. Apply some pipe thread sealant to the quick release valve and carefully screw the valve into the nylon elbow.
4. Apply some thread sealant to the brass connector and carefully screw the whole assembly into the brass insert in the tank.
5. Connect the short hose of the Eliminator hose assembly to this tank connection.

Spraymate 30, Spraymate 100, and Sprayrider 45 & SO200 sprayers

The following additional parts (not supplied in parts kit) are required to connect the return line quick release valve to the SM30, SM100, and SR45 tanks:

<i>Part No.</i>	<i>Description</i>	<i>QTY</i>
4500-1300	Bypass provision asy	1

1. Using a 12.5mm drill, drill a hole in the top of the tank.
2. Apply some thread sealant to the male thread on the brass reducer and screw it into the nylon elbow from inside the tank.
3. Apply some thread sealant to the brass quick release valve and screw it into the nylon elbow.
4. Connect the short hose of the Eliminator hose assembly to the tank quick-release valve.

Control Panel

1. Unplug the cable assembly supplying power to the sprayer.
2. Connect the control cable between the power cable and the sprayer.
3. Attach the control box to the ATV using the self-adhesive Velcro pad provided.

TESTING

1. Part fill the tank with fresh clean water.
2. Turn on the pump using the switch on the control panel. The pump will cycle on and off, turn the control knob to '7'

CAUTION

When using the electronic control panel it is essential that the sprayer battery cable be correctly connected. If incorrect polarity is applied to the control panel the internal protection circuit will cause the fuse will blow. Repeat applications of power will eventually damage the protection circuit. If the fuse blows, check the polarity of the battery cable before replacing the fuse.

3. Check that there are no leaks in the hose connections.
4. Allow the carpets to become wet until dripping. The flow rate from each carpet should be the same and should cause even wetting along the entire length of each carpet.

NOTE

When the wiper is used for the first time, it may be necessary to break the surface tension of the woolen wiper pads. Mix up some detergent and tip it over the wiper pads.

WIPING

For best results the following points should be noted:

- a. Use clean fresh water, preferably tank water.
- b. It is advisable to graze pasture well before wiping to maximise the weed's exposure to the wiper.
- c. Remove excessive dead material in weeds such as rushes and fern by hard grazing or burning then wipe the fresh re-growth.
- d. Avoid low humidity, hot, dry conditions.
- e. The weeds should be actively growing and not under any stress.
- f. Use an adjuvant such as "C-Dax OIL" - see section 'adjuvants'
- g. Prevent mud, dust and dirt from getting on the carpets. This can easily occur during transport. Put mud-flaps on the towing vehicle.

CHEMICAL APPLICATION

Chemical Advice

C-Dax Limited or their agents cannot make recommendations or give advice as to the use of chemicals and cannot accept responsibility for any damage, injury or other consequence for disregarding this warning notice. Contact your chemical supplier for advice.

WARNING

Mixing chemicals is a most dangerous activity as it involves handling the concentrated material. For toxic compounds, use protective clothing such as overalls, hat, gloves, boots and respirator.

When using diluted sprays, wear at least a hat, long-sleeved cotton overalls, and boots. If you use pesticides regularly, it is a good idea to always wear a respirator to avoid accumulation of toxins in the body. Other protection may be required. Check the label for specific directions for the particular chemical.

Protective clothing should be properly cared for. Rinse contaminated clothes in the open before washing in the laundry – be sure to keep separate from other washing.

Respirators need special care. Clean respirator after spraying. Use soapy water then rinse and allow to dry completely before storing in a clean plastic bag. Replace canisters in respirator after eight hours use.

Purchasers must ensure that operators of these machines are fully aware of the dangers of spraying chemicals.

Herbicide Rates

The following mixing ratios (chemical : water plus adjuvant) have been found more than adequate by Eliminator users:

- | | |
|--|--|
| • 24-D (annual thistles) | 1 : 10 |
| • Escort (ragwort) | 1 gram : 1 litre |
| • Glyphosate (rushes, Californian thistle, Fescue) | 1 : 20 to 1 : 10 |
| • Tordon Max (Californian thistle, Ragwort) | 1 : 20 (single pass)
1 : 40 (double pass) |

Example

Glyphosate (e.g. 'Roundup') at 1 : 10 in 100-litre tank could be mixed with water and adjuvant in the following ratios: 10 litres Glyphosate, 89 litres of water and 1 litre of C-Dax OIL (In this case C-Dax OIL is added last).

Adjuvants

Adjuvants are ingredients added to a pesticide to improve its performance.

The use of an adjuvant such as C-Dax OIL is recommended when wiping. They improve capillary action in the carpet, increase viscosity for better flow of the chemical solution, and improve adhesion and uptake into plant surfaces.

Thoroughly mix the herbicide and any adjuvants, with the water according to the instructions from the herbicide and adjuvant manufacturers. In the case of water based chemicals, add C-Dax OIL last. With oil based chemicals mix the chemical and C-Dax OIL together prior to adding to the water.

Begin wiping soon after filling the tank.

If a solution has been left standing for more than two hours stir it, or if a tank agitation system is available, turn it on.

CALIBRATION

Height Adjustment

Run the wiper over the weeds and check that the height is suitable. Set the wiper as low as possible without running the risk of causing damage to the pasture, crop or frame. Whilst the Eliminator has been designed to withstand ground strikes, it should not be set so low that ground strikes re occur. Remember, the wiper is not a bulldozer.

The eliminator has four height settings shown below. The draw bar can be inserted into one of two holes and the wheel has four adjustment holes. The swivel tow hitch also allows the draw bar to be inserted upside down.

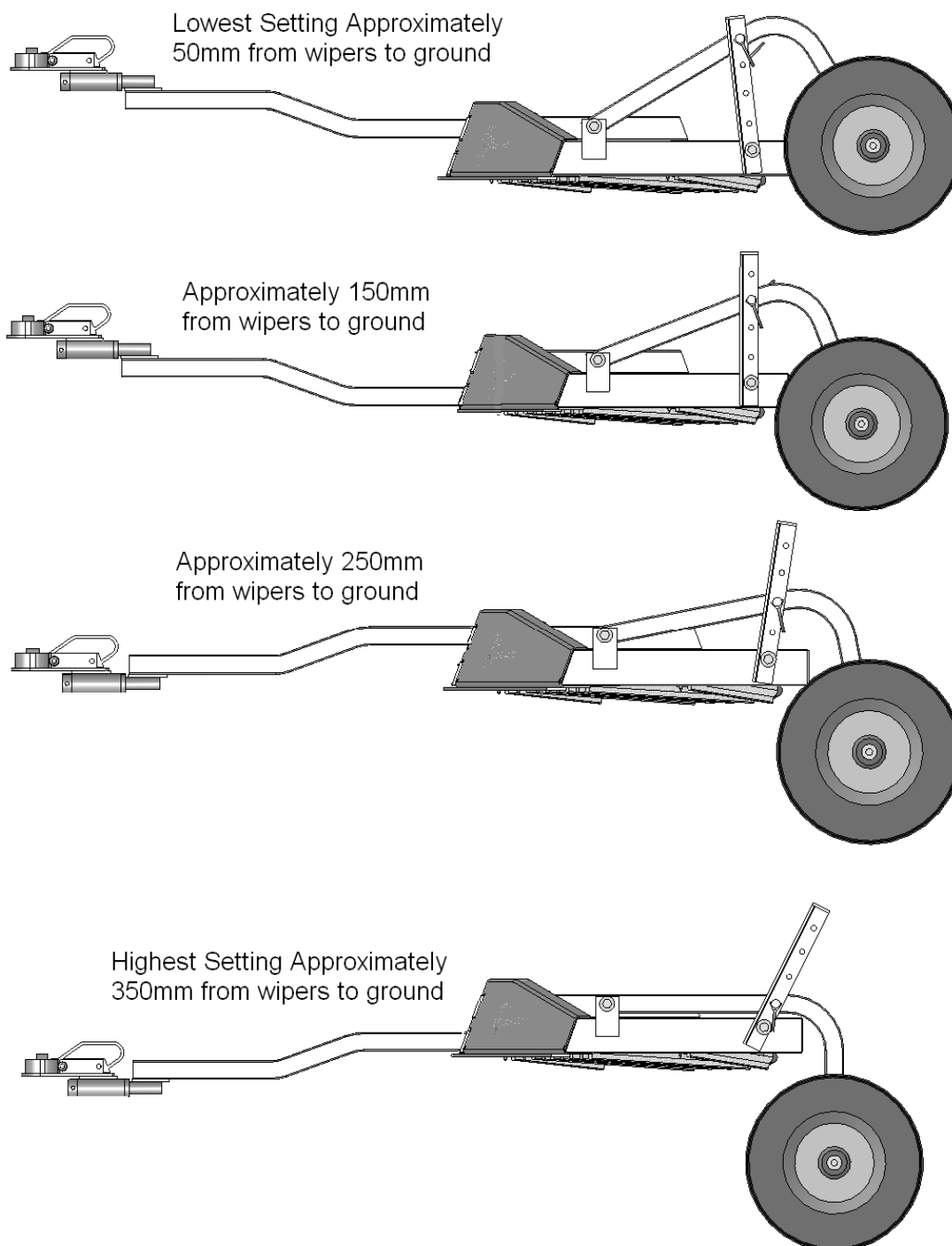

On the Winged Eliminator unit the wings are self angling and as such the unit can only be set approximately level when the height adjusters are on the second hole from the top.

Application Rates

The Eliminator can be set up for medium or high application rates. For medium rates, a flow plate marked M (#37) is fitted in the delivery line to the wiper. This is the standard configuration. If a high application rate is required, a large flow plate marked L (#55) can be fitted. The flow plate in the bypass line is always a #63.

To change the flow plate, refer to the figure on page 7. Remove the nut connecting the delivery tube from the wiper to the white tee. Take care not to drop the check valve strainer when the nut is removed. Remove the M (#37) flow plate and replace it with the L (#55) flow plate provided in the parts kit. Ensure that the check valve strainer is in place then replace the nut.

The control unit settings provide the following approximate flow rates. Also shown are the average application rates per hectare at 8 kph.

Medium Rates (M Flow Plate #37)

1 - 120 ml/minute (4 l/ha)	5 - 500 ml/minute (16 l/ha)
2 - 240 ml/minute (7.5 l/ha)	6 - 600 ml/minute (19.5 l/ha)
3 - 340 ml/minute (11 l/ha)	7 - 670 ml/minute (21.5 l/ha)
4 - 430 ml/minute (14 l/ha)	

High Rates (L Flow Plate #55)

1 - 240 ml/minute (8.5 l/ha)	5 - 926 ml/minute (30 l/ha)
2 - 411 ml/minute (13 l/ha)	6 - 1083 ml/minute (35 l/ha)
3 - 616 ml/minute (20 l/ha)	7 - 1246 ml/minute (40 l/ha)
4 - 786 ml/minute (25.5 l/ha)	

The above data is only applicable to non winged Eliminators. The Winged Eliminator is fitted with a #52 flow plate (and a #63 in the bypass line) which provides approximately 0.53 lpm to the centre section and 0.2 lpm to each wing when the pump is running continuously. If the controller is used with the Winged Eliminator, the flow rate will be reduced proportionally to the setting on the controller. There should not be a need to change the flow plate on the Winged Eliminator. If one of the wings is being operated independently of the other then adjustment can be made on the controller to maintain the desired application rate.

Maximum Speeds

The Eliminator can be towed at up to 15 Kph. However when wiping the following speeds have been found to be effective;

- a. Sparse infestations of easy to kill weeds (e.g. Scotch Thistle) - 12 kph.
- b. Very thick undulating infestations, (e.g. Rushes and Bracken) - 5 to 8 kph.

WARNING

Operation of the Eliminator at high speed over rough ground may damage the frame. Do not allow the Eliminator to bounce or hit fixed objects.

Setting the Flow Rate

Set the electronic control unit to mid-range for the first round. Visibly inspect the weeds and wipers after the first round. The carpets should be moist without dripping.

Use the higher number on the electronic controller for dense weed growth.

Trials have shown that the control knob on the electronic controller is not usually required to be set above '3'. Bear in mind, whilst the carpets are wet, they are applying herbicide to the target plants and doing their job.

MAINTENANCE

Flushing

Flush the tank and wiping system before storing. Set the controller to 7, or couple the pump direct to the battery lead so that the pump runs continuously.

Flush once with clean fresh water and detergent, then twice with clean water. Allow at least 4 minutes each time. During the flushing procedure, hose the carpets down with clean water to remove any dirt or other matter.

Check for even flow from all carpets.

Allow the carpets to dry out then store in a clean dry shed out of sunlight.

Wash any dust from the carpets before the next use.

Filters

After each use, remove the nuts from the tee in the hose assembly, check the strainers, and flow plates for blockages.

CAUTION

After cleaning the flow plates and strainers, ensure that the M flow plate and check valve strainer are fitted in the connection to the delivery line to the wiper, and that the #63 plate and non-check valve strainer are fitted in the bypass line to the tank. Failure to correctly install the flow plates and strainers will result in defective operation of the wiper.

Carpets

Inspect the wipers regularly and replace any that are badly worn or torn.

Frame

Inspect the bolts and tighten if loose. Never operate the wiper with loose bolts.

On Winged Eliminator units regularly check the condition and engagement of the latch mechanisms that hold the wings in the upright position. The latches should fully engage the catches on the wings.

Wheels and Tyres

Lubricate the axles after each use and check the tyre pressures. The correct tyre pressure is 15 psi (100KPA).

TROUBLE SHOOTING

PROBLEM	CAUSE	ACTION
Insufficient flow from ALL carpets	1. Faulty pump	Return to supplier for service
	2. Blocked suction filter	Clean
	3. Blocked flow plate or filter at check valve on hose to wiper	Clean
	4. Kinked hose	Straighten
Insufficient flow from one carpet	1. Blocked soak line under carpet	Remove carpet and check. Replace or clean
	2. Blocked hose tail connector at base of yellow carpet pipe	Flush and wash down carpets
Uneven wetting along a carpet.	1. Partial blocking of soak line under carpet.	Remove carpet and check soak line.
	2. Carpets not cleaned properly	Replace or clean Flush and wash down carpets
Too much flow from carpets	1. Pump operating for too long	Reduce pumping interval
	2. Flow plates incorrect	Check and correct
High initial flow from carpets when pump turns on	1. Blocked flow plate or filter at check valve on the by-pass hose	Clean
Pump fails to prime	1. Faulty pump	Return to supplier for service
	2. Air in suction line	Check connections for leaks
Pump fails to operate	1. Faulty Electronic controller	Return to supplier for service
	2. Faulty electrical connection	Check connections
	3. Faulty pump	Return to supplier for service
Fuse blows each time power is applied	1. Battery cable connected incorrectly	Check battery connections and reverse if required

EXPLODED PARTS DIAGRAM

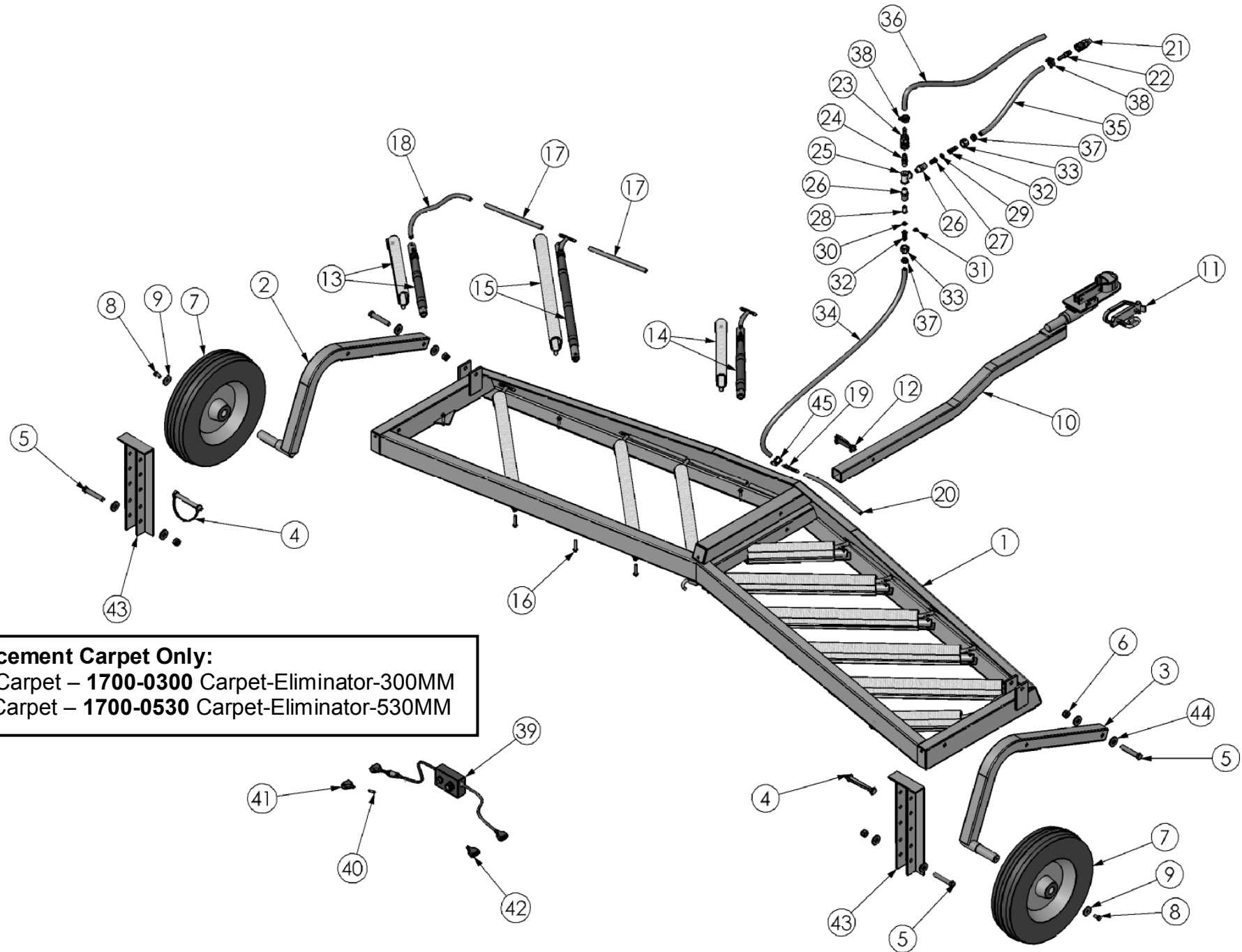

Replacement Carpet Only:
 Short Carpet – 1700-0300 Carpet-Eliminator-300MM
 Long Carpet – 1700-0530 Carpet-Eliminator-530MM

PARTS LIST

ITEM NO.	QTY.	Part No	DESCRIPTION
1	1	3500-7800	Frame-Wiper-Eliminator-GL
2	1	1082-2400	Axle-Eliminator G2-LH-ZP
3	1	1082-2401	Axle-Eliminator G2-RH-ZP
4	2	6100-4800	Pin-Locking-11x100mm-ZP
5	4	2840-1290	Fastener-Bolt&Nut-Hex-8.8 Grade-M12x90-ZP
6	4	3170-0012	Fastener-Nut-Nyloc-M12-ZP
7	2	9200-7500	Wheel-Ribbed-350x8-4 Ply-3 Ribs-BW Series
8	2	2840-0816	Fastener-Bolt&Nut-Hex-8.8 Grade-M8x16-ZP
9	2	3310-3008	Fastener-Washer-Flat-Fender-M8x32x1.5-ZP
10	1	2550-2300	Drawbar-Eliminator-ZP
11	1	8800-3800	Tow-Coupling-Handle-Double Ended-1 7/8" x 50mm-ZP
12	1	6100-4780	Pin-Locking-10x57mm-ZP
13	2	1700-2300	Carpet-Wiper Assembly-Eliminator-Outer-300mm
14	2	1700-1300	Carpet-Wiper Assembly-Eliminator-Inner-300mm
15	8	1700-1530	Carpet-Wiper Assembly-Eliminator-530mm
16	24	3300-6100	Fastener-Tek Screw-Hex-12Gx45-Hitek-Fully Threaded-ZP
17	8	4100-1006	Hose-Spray-Delivery-7 Bar-6mm ID-PVC (220LG)
18	1	4100-1006	Hose-Spray-Delivery-7 Bar-6mm ID-PVC (300LG)
19	1	6200-9130	Pipe-Fitting-Tee-6 Shankx6 Shankx6 Shank-Plastic
20	1	4100-1006	Hose-Spray-Delivery-7 Bar-6mm ID-PVC (300LG)
21	1	6200-7240	Pipe-Fitting-Quick Release-Valve-1/4BSPM-Brass
22	1	6200-7210	Pipe-Fitting-Quick Release-Male Connectorx8.5 Shank-Brass
23	1	6200-7250	Pipe-Fitting-Quick Release-Valve-Stopx8.5 Shank-Brass
24	1	6200-7200	Pipe-Fitting-Quick Release-Male Connectorx1/4BSPM-Brass
25	1	6200-9100	Pipe-Fitting-Tee-1/4BSPFx1/4BSPFx1/4BSPF-Plastic
26	2	6200-7380	Pipe-Fitting-Reducer-1 1/16UNCMx1/4UNFM-Straight-Plastic
27	1	3400-5400	Filter-Nozzle Tip-50 Mesh-Plastic
28	1	3400-5410	Filter-Nozzle-Tip-Incl Check Valve-50Mesh-5PSI-SS Ball-Plastic
29	1	5300-5100	Nozzle-Plate-Teejet-Orifice-0.063in-SS
30	1	5300-5000	Nozzle-Plate-Teejet-Orifice-0.055in-SS
31	1	5300-4800	Nozzle-Plate-Teejet-Orifice-0.037in-SS
32	2	6200-8220	Pipe-Fitting-Straight-10 Shank-Swivel-Suit Fly Nut-Plastic
33	2	6200-5550	Pipe-Fitting-Nut-Swivel-1 1/16UNFF-Plastic
34	1	4100-0008	Hose-Spray-Delivery-40 Bar-8.5mm ID-Yellow
35	1	4100-0008	Hose-Spray-Delivery-40 Bar-8.5mm ID-Yellow
36	1	4100-0008	Hose-Spray-Delivery-40 Bar-8.5mm ID-Yellow
37	2	2000-2014	Clamp-Hose-Oetiker-Single Ear Stepless-14.5<>7.0mm-S/S
38	2	2000-0013	Clamp-Hose-Herbi-E-Ratchet-13.1<>15.1mm-Black-Nylon
39	1	1500-4300	Cable-Electrical-Loom-Eliminator-Control Box
40	1	3600-1010	Fuse Link-Electrical-Standard Blow-15 Amp-1"x1/4"-Glass
41	1	6250-3001	Plug-Electrical-2 Pin-Male-20 Amp-With Cover
42	1	6250-3000	Plug-Electrical-2 Pin-Female-20 Amp-With Cover
43	2	1018-3920 LH 1018-3921 RH	Adjuster-Height-Eliminator-ZP
44	8	3310-5012	Fastener-Washer-Flat-Heavy-M12x32x3-Galv
45	1	2000-4008	Clamp-Hose-Worm Drive-Jubilee-8mm-Stainless

Winged Eliminator Assembly Diagram

ITEM NO.	QTY.	Part No	DESCRIPTION
1	1	3500-7500	Frame-Wiper-Eliminator Winged-GL
2	1	1082-2400	Axle-Eliminator G2-LH-ZP
3	1	1018-3920	Adjuster-Height-Eliminator-LH-ZP
4	4	3170-0012	Fastener-Nut-Nyloc-M12-ZP
5	4	2840-1290	Fastener-Bolt&Nut-Hex-8.8 Grade-M12x90-ZP
6	4	3310-5007	Fastener-Washer-Flat-Heavy-M8x22x3-ZP
7	8	3310-5012	Fastener-Washer-Flat-Heavy-M12x32x3-Galv
8	2	3170-0008	Fastener-Nut-Nyloc-M8-ZP
9	1	3500-7600	Frame-Wiper-Eliminator Wing-LH-GL
10	1	4680-2300	Latch-Eliminator Wing-LH-ZP
11	2	2840-0840	Fastener-Bolt&Nut-Hex-8.8 Grade-M8x40-ZP
12	2	6100-4780	Pin-Locking-10x57mm-ZP
13	2	9200-7500	Wheel-Ribbed-350x8-4 Ply-3 Ribs-BW Series
14	14	1700-1530	Carpet-Wiper Assembly-Eliminator-530mm
15	4	1700-1300	Carpet-Wiper Assembly-Eliminator-Inner-300mm
16	4	1700-2300	Carpet-Wiper Assembly-Eliminator-Outer-300mm

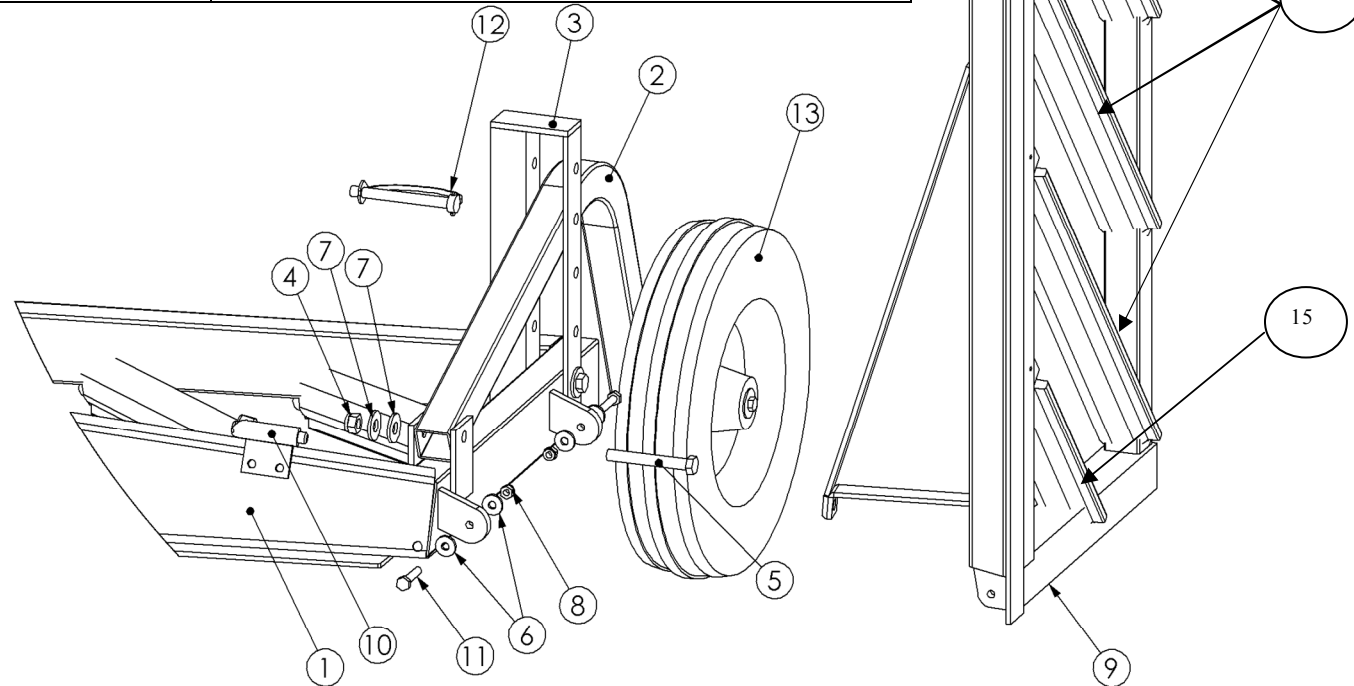

Notes: