

# ASSEMBLY INSTRUCTIONS

**AcEASE**

Kunz Engineering Inc.

Mendota, IL

Electric Lift Kit 003909

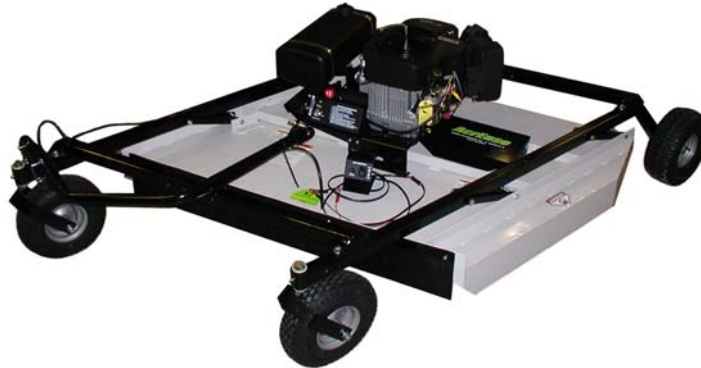

## READ THE COMPLETE ASSEMBLY INSTRUCTIONS BEFORE STARTING THE ASSEMBLY.

**You should have the following parts with the electric lift kit:**

- one upper actuator mount and one upper actuator mount assembly
- lower actuator mount assembly
- lift control wiring assembly
- hardware package



**Before doing any installations or adjustments, shut off mower engine.**

### A. CARRIER ARM PREPARATION (Refer to Figure 1.)

1. If your mower's carrier arms currently have the designated holes shown in Figure 1, refer to section B. If the electric lift kit and mower were purchased from the manufacturer at the same time and the lower actuator mount assembly is currently installed (See Figure 2), refer to section C. For carrier arm, rear wheel and tongue installation, refer to the main owner's manual.
2. To locate the hole position on the carrier arms, measure from the front edge to the described distance for each hole position. For a more accurate measurement, it is best to determine the second hole position in relationship to the first hole position. This should help reduce error in hole positioning and ease in the assembly process. The first hole should be set at 7" from the front edge of the carrier arm. The second hole should be positioned 3-25/32" (3.78") from the first holes position. The third hole should be located at 65-9/16" (65.56") from the front edge of the carrier arm. The fourth hole should be positioned 3-25/32" (3.78") from the third holes position. Repeat the hole positioning on the second carrier arm.
3. Using a 17/32" (.531") drill bit, drill all eight holes. Take care to drill straight through the carrier arms.

**Note:** Hole misalignment from top to bottom may cause difficulty during assembly.

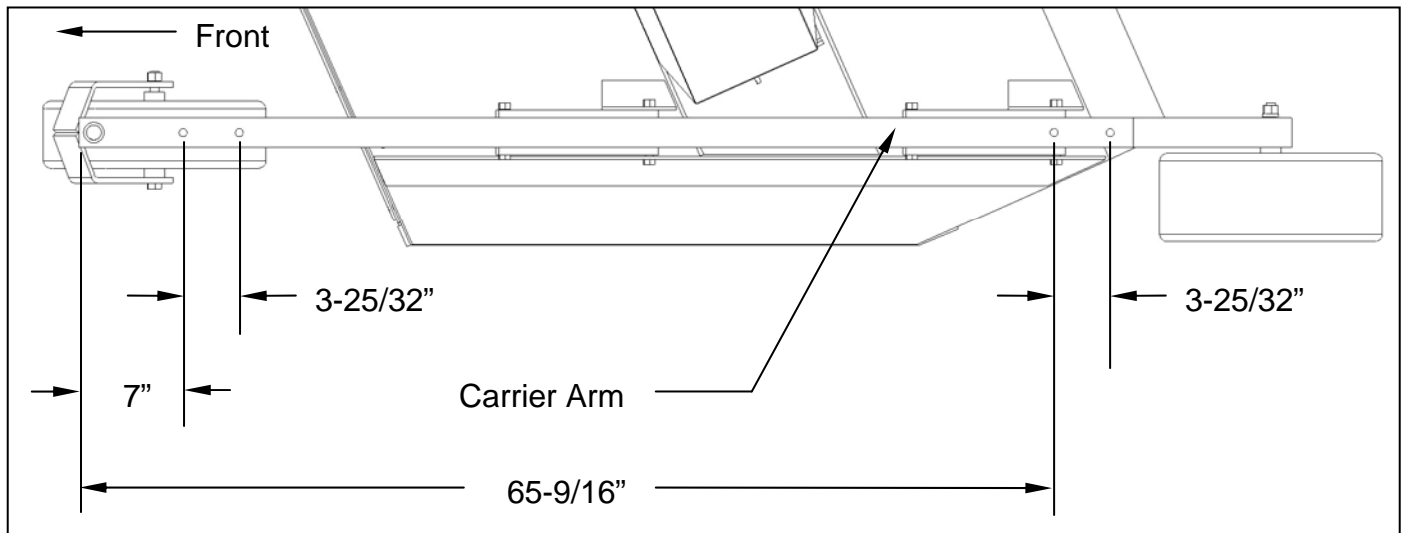

Figure 1. Carrier Arm Hole Location

**B. LOWER ACTUATOR MOUNT ASSEMBLY INSTALLATION (Refer to Figure 2.)**

1. Remove the two bolts that fasten the rear portion of the engine support bracket to the main frame of the deck.
2. Remove the two 5/16" x 3/4" bolts and two 5/16" x 1" bolts from the lower actuator mount assembly. Position the lower actuator mount assembly on the deck as shown in figure 2 and align the holes on the lower actuator mount, engine support bracket and deck frame. Insert the two 5/16" x 1" bolts and fasten securely with lock washers and nuts.
3. The two remaining hole positions on the lower actuator mount can now be used as a drilling guide for drilling the two remaining mounting holes in the deck. Using a 11/32" (.344") drill bit, drill the two remaining holes.

**Note:** Depending on the model of rough cut mower, it may be necessary to drill at a slight angle. On the twin cylinder engine models, it may be necessary to remove the air cleaner in order to get a more direct approach. If the air cleaner is removed, take care to cover the carburetor to prevent debris from entering.

4. Insert the two 5/16" x 3/4" bolts into the newly drilled holes and fasten securely with lock washers and nuts.

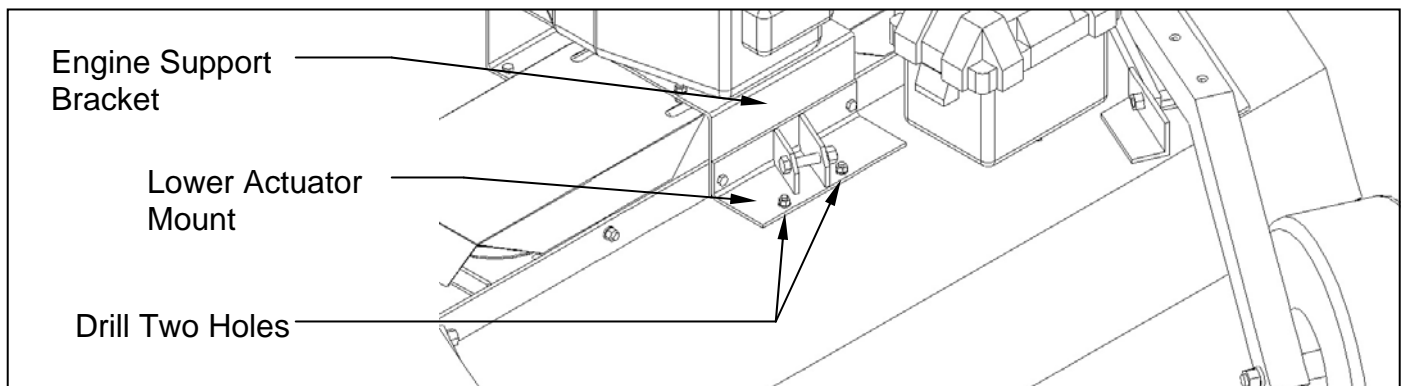

Figure 2. Lower Actuator Mount Assembly

### C. INSTALLATION OF UPPER ACTUATOR SUPPORTS AND ACTUATOR

1. For models with the crank height adjust system, at this time it will work best to lower the deck down on several blocks of wood. This will take the load off of the carrier arms and help to align the upper actuator supports.
2. If your mower has the crank height adjust system, remove both bolts that mount the crank system.
3. Install the upper actuator supports on the carrier arms with the provided 1/2" x 3" hex head bolts, lock washers and nuts. Only hand tighten the hardware for this step. The support that has the electric linear actuator fastened to it needs to be placed on the rear location. Orientate the support such that the actuator hangs towards the engine. **See figure 3.**

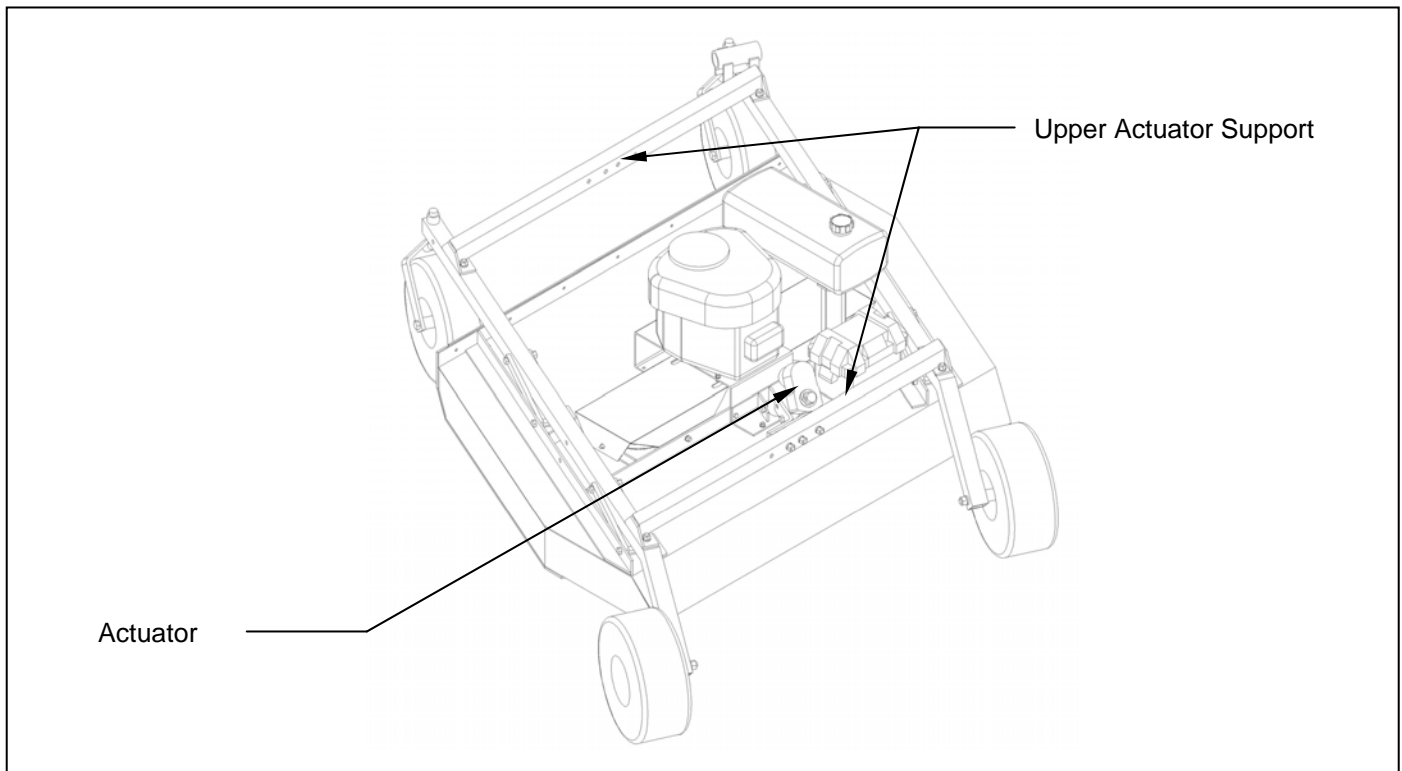

Figure 3: Upper Actuator Support Installation

4. Remove the 1/2 " X 2-1/2" bolt and lock nut from the lower actuator mount. By hand, turn the actuator cylinder out clockwise until the actuator cylinder hole aligns with the lower actuator support. After achieving alignment, attach the actuator cylinder with the 1/2" x 2-1/2" hex head bolt and secure the bolt with the provided lock nut. **See figure 4.**



**Do not attempt to align the actuator cylinder and lower actuator support with the electric function of the actuator. Doing so could result in severe bodily injury.**

5. Attach the battery clips on the lift control wiring assembly to the appropriate terminals on a battery (red attaches to the positive terminal and black to the negative terminal). Stand back and activate the appropriate “up” switch. Raise the mower to its highest position and stop. At this time securely tighten the 1/2” x 3” hex head bolts, lock washers and nuts holding the upper actuator supports in place. This step insures that proper alignment of the carrier arms has been achieved.



**Always stand clear of the mower when raising up or down. Severe bodily injuries can occur at various pinch points.**

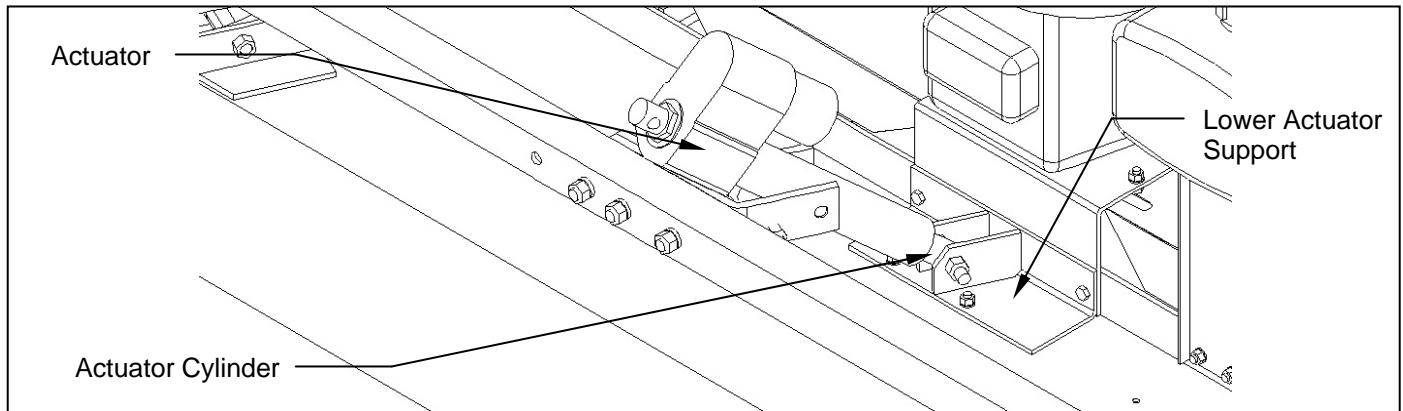

Figure 4. Actuator and Lower Actuator Support Alignment

#### D. INSTALLATION OF THE LIFT CONTROL WIRING ASSEMBLY

1. Using the provided “U” bolts, securely fasten the lift control panel to the tow vehicle. On most ATVs, the “U” bolts will allow easy installation on the rack.
2. There are two separate electrical cables extending from the lift control panel. There should be a cable that contains battery clips and another cable that has a connector attached to the end. Attach the connector side to the actuator connector. Attach the battery clips to the appropriate terminals on a battery (red attaches to the positive terminal and black to the negative terminal).

**Note:** Extra electrical cable length can be purchased (**Extension Cable Part #235067**) if needed. In some applications it may be necessary to have extra length to reach the battery or reposition the lift control panel.

4. Securely fasten the electrical cable that extends back to the actuator. Using the provided plastic ties, fasten the cable to the upper actuator support, carrier arms and tongue. Excess cord should be left at the point of the tongue and hitch pivot to allow for tongue adjustments. Position the disconnect plug such that it can be easily disconnected when the mower is removed from the rear of the tow vehicle.

## **ELECTRIC LIFT KIT PARTS LIST**

<b><u>Item</u></b>	<b><u>Part #</u></b>	<b><u>Description</u></b>	<b><u>Quantity</u></b>
1	235061	Six Contact Socket Connector	1
2	235063	Battery Wiring Harness	1
3	235065	Wiring Harness	1
4	235066	Battery Clip Harness	1
5	235067	Extension Cable	1
6	235070	Actuator Wiring Harness Assy.	1
7	237000	Electric Linear Actuator (8" Stroke)	1
8	264006	Fuse Holder	1
9	264008	Rocker Switch	1
10	277030	Fixed Diameter Cable Clamp	2
11	500010	Control Panel	1
12	600185	Top Long Support	1
13	600186	Top Short Support	1
14	900092	Lower Actuator Support	1
15	900093	Upper Actuator Support	2

# ELECTRIC LIFT KIT PARTS

